

GTH 250

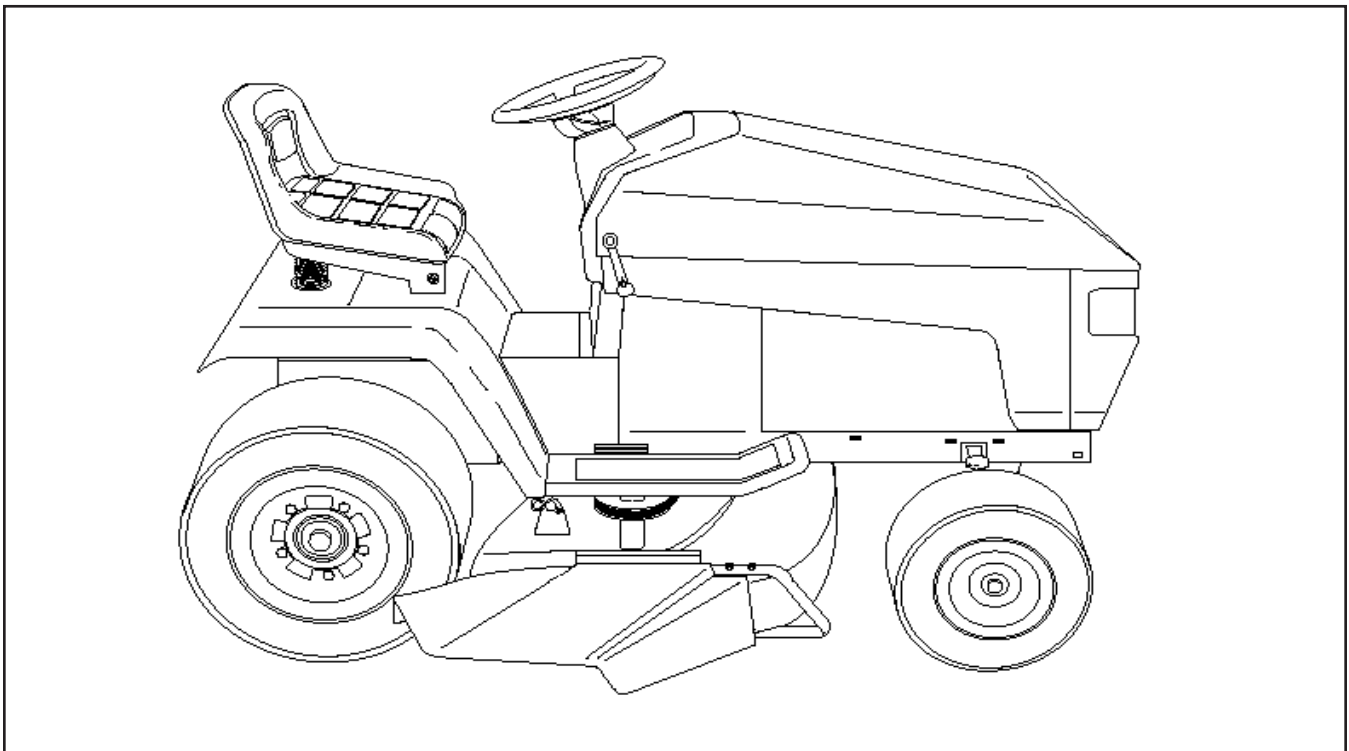

Ride Mower

954140104B

REPAIR PARTS

TRACTOR - MODEL NO. GTH250 (954140104B), PRODUCT NO. 954 14 01-04

ELECTRICAL

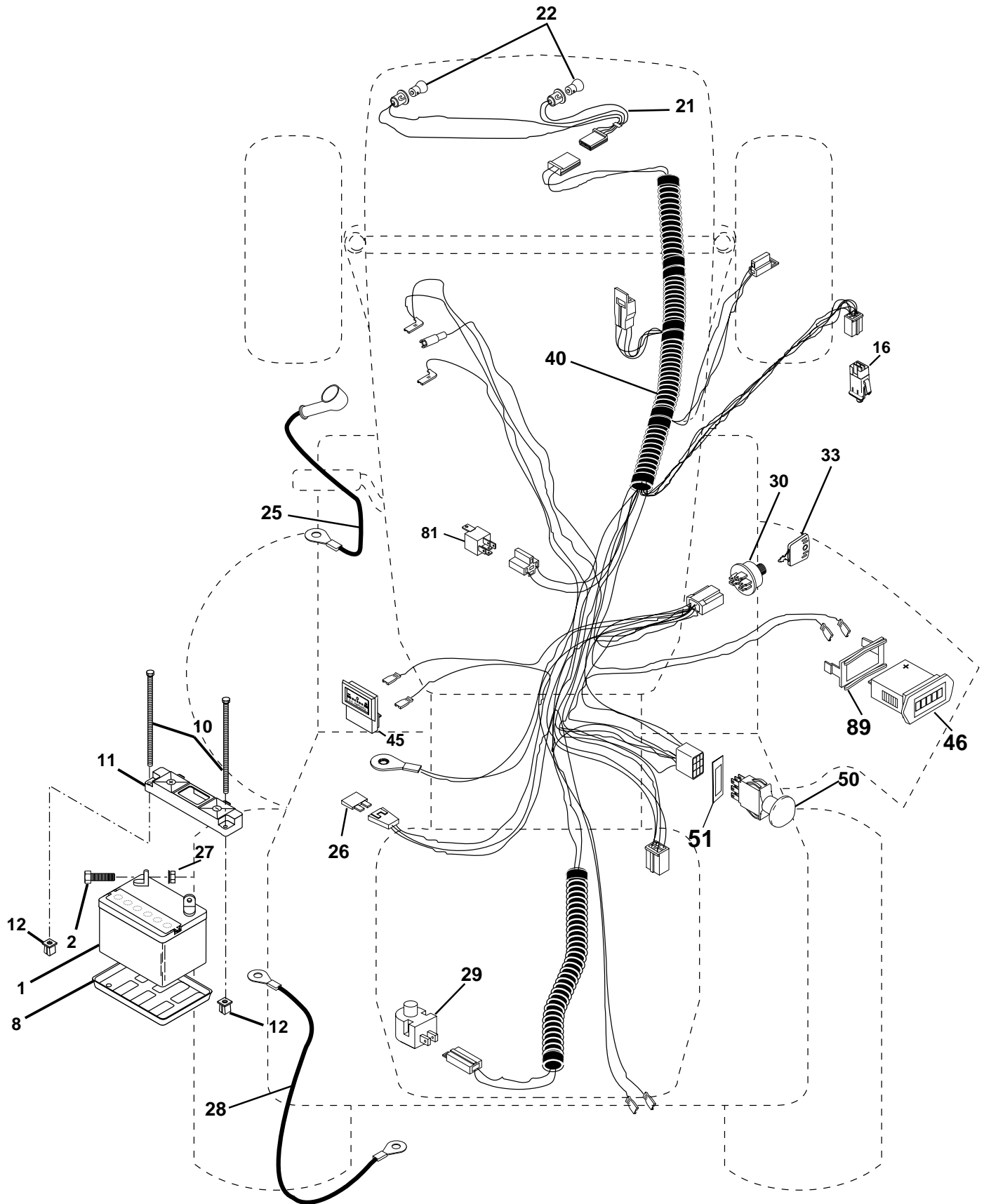

REPAIR PARTS

TRACTOR - MODEL NO. GTH250 (954140104B), PRODUCT NO. 954 14 01-04

ELECTRICAL

KEY NO.	PART NO.	DESCRIPTION
1	532144927	Battery
2	532171017	Bolt Hex Head 1/4-20 x 3/4
8	532124886	Tray, Battery
10	532171327	Bolt, Btr Frt 1/4-20 x 7-1/2 Zinc
11	532150109	Holddown Battery Front Mount
12	532145769	Nut Push Nylon 1/4" Battery Frt.
16	532153664	Switch Interlock Push-In
21	532166182	Harness Socket Light w/4152J
22	532004152	Bulb Light
25	532154335	Cable/Boot Asm. CV25
26	532108824	Fuse
27	532171018	Nut Keps Hex 1/4-20 Unc
28	532170697	Cable, Ground
29	532160784	Switch, Plunger
30	532163968	Switch, Ign
33	532140401	Key
40	532166178	Harness Ign.
45	532122822	Ammeter, Rectangular 15 Amp
46	532169635	Meter Hour Snap-In
50	532169417	Switch, PTO
51	532140405	Ring Retainer PTO
62	532110143	Bulb, Light Pkg.
81	532109748	Relay Asm.
89	532169639	Bracket Snap-In Hourmeter

NOTE: All component dimensions given in U.S. inches
1 inch = 25.4 mm

REPAIR PARTS

TRACTOR - MODEL NO. GTH250 (954140104B), PRODUCT NO. 954 14 01-04

CHASSIS AND ENCLOSURES

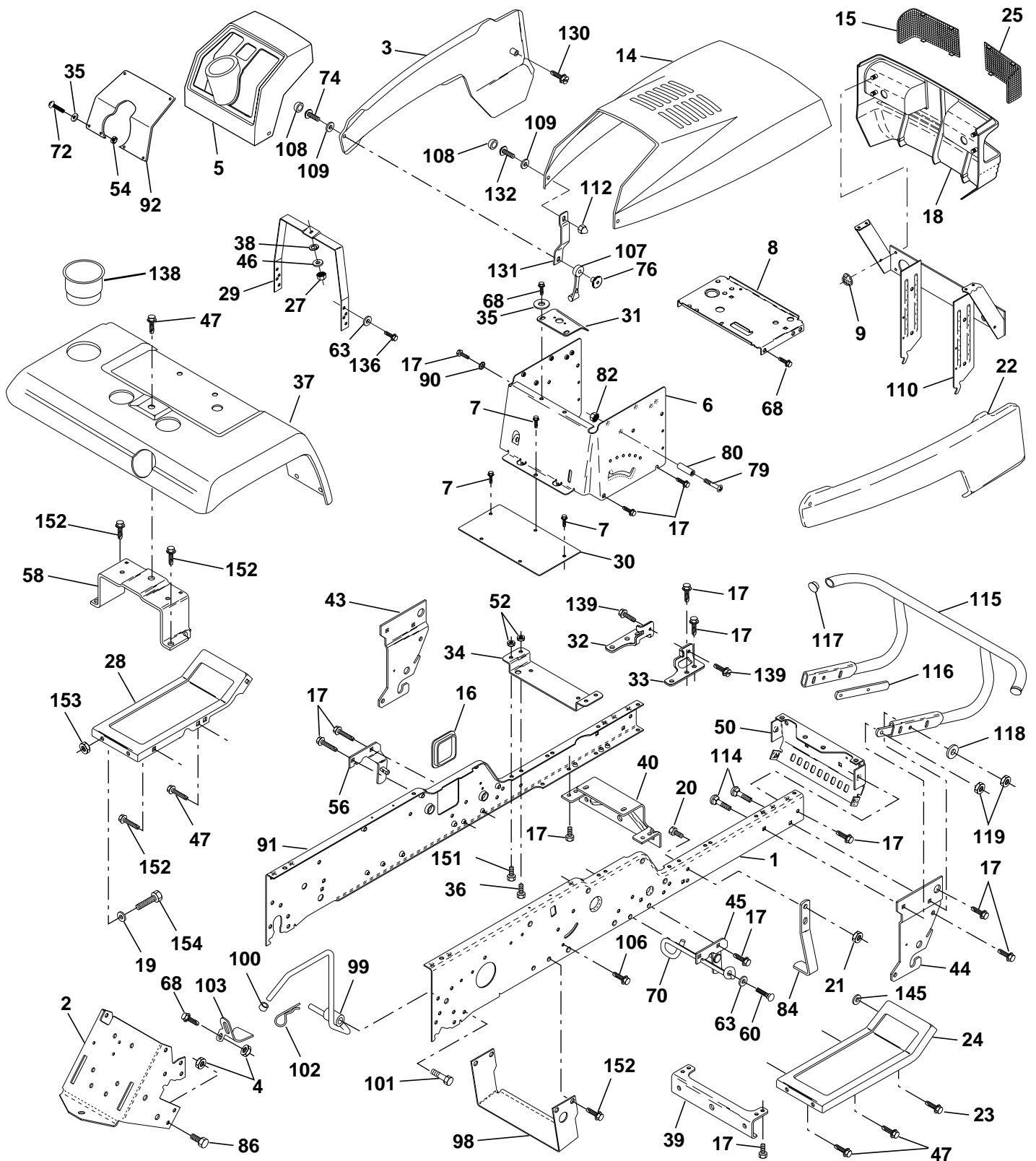

REPAIR PARTS

TRACTOR - MODEL NO. GTH250 (954140104B), PRODUCT NO. 954 14 01-04

CHASSIS AND ENCLOSURES

KEY NO.	PART NO.	DESCRIPTION	KEY NO.	PART NO.	DESCRIPTION
1	532150253	Rail, Frame RH	63	532171236	Washer 13/32 x 1 x 14 Ga.
2	532140506	Drawbar, Gt	68	532171196	Screw, Thdrol 5/16-18 x 1/2
3	532150478	Panel Asm., Side LH	70	532137159	Guide, Belt Mid Span
4	532171331	Nut, Crownlock 7/16-14 Unc	72	532171194	Screw, Mach Trhd 5/16-18 x 3/4
5	532140452	Dash, Plastic Black	74	874191008	Screw, Machine #10-24
6	532157882	Dash 1-PCS, Lower	76	532125004	Nut, Weld #10-24
7	532171323	Screw, Thd Cut 1/4-20 x 1/2	79	532171346	Screw, Machine #10-24 x 1/4
8	532145166	Support, Battery	80	532171345	Spacer, Split
9	532108067	Nut Pal	82	532171347	Nut #10-24
14	532150477	Hood Asm., Pnt	84	532142992	Stop, Over Center 44" 20/23" T. 94
15	532168214	Lens, Headlight LH	86	532171330	Bolt, Fin Hex 7/16-14 Unc x 1
16	532121794	Cover, Access	90	532171217	Washer, Lock External Tooth 3/8
17	532171167	Screw 3/8-16 x 3/4	91	532170755	Rail, Frame Lh
18	532157236	Grille	92	532171366	Plate, Silkscreen Dash
19	532171151	Washer 13/32 x 13/16 x 12 Ga.	98	532140503	Bracket Chassis Skid
20	532171339	Bolt, Fin Hex 3/8-16 x 1	99	532171332	Rod Asm. Bypass
21	532171168	Nut, Crownlock 3/8-16 Unc	100	532071673	Cap Brake Parking Black
22	532150479	Panel Asm., Side RH	101	532171334	Screw Thdrol. 3/8-16 x 1-3/4
23	532171235	Screw 3/8-16 x 1/2	102	532171333	Retainer Spring 1"
24	532147202	Footrest, RH	103	532142273	Bracket Lock Bypass
25	532168213	Lens Headlight RH	106	532171341	Screw Thdrol. Hex Hd Zinc Mur
27	532171343	Nut Fin Hex 1/4-20	107	532109808	Latch, Chute Blk
28	532147203	Footrest, LH	108	532110356	Cap, Snap Black
29	532145205	Bracket, Support Dash	109	532110357	Cap, Washer Snap
30	532145052	Saddle	110	532150200	Pivot Asm. Grille/Hood Husq. VGT
31	532161419	Brace, Support Steering	112	532060867	Nut, Acorn, Hex #10-24
32	532161327	Bracket Asm., Frame Pivot Lh	114	532171335	Bolt, Carriage 3/8-16 x 1-1/4
33	532161326	Bracket Asm., Frame Pivot Rh	115	532150300	Bumper Asm.
34	532142131	Bracket, Engine Support Rear	116	532141461	Bracket Extension Bumper
35	532171349	Washer 11/32 x 11/16 x 16 Ga.	117	532143679	Plug Plastic
36	532171338	Bolt, Fin Hex 5/16-18 x 3/4	118	532171140	Washer 13/32 x 13/16 x 16 Ga.
37	532169426	Fender, Pnt.	119	532171141	Nut Crownlock 3/8-16 UNC
38	532171185	Washer, Lock 1/4	130	532171223	Screw HWHD Hi-Lo #13-16 x 3/4
39	532136961	Bracket, Axle Front	131	532150195	Bracket Support Hood/Panel YP
40	532156111	Bracket, Support Axle/Engine	132	874291006	Screw Truss Hd. #10-24 x 3/8
43	532136939	Bracket, Spnsn Front Lh	136	532171154	Screw 3/8-16 x 3/4
44	532136940	Bracket, Spnsn Front Rh	138	532166625	Cupholder YTTGT Grey
45	532154913	Bracket Asm., Susp Chassis Rh	139	532171348	Bolt, Shoulder 5/16-18 TT
46	532171342	Washer 9/32 x 3/4 x 16 Ga.	145	532171465	Washer Flat 13/32 x 7/8 x 16 Ga.
47	532171136	Screw Thdrol 3/8-16 x 1/2	151	532171340	Screw 5/16-18 x 3/4
50	532152728	Bracket, Chassis Front	152	532171154	Screw 3/8-16 x 3/4
52	532171248	Locknut, Hex W/Ins 5/16-18 Unc	153	532171141	Nut Crownlock 3/8-16 Unc
54	532171195	Nut 5/16-18	154	532171375	Bolt Hex Fin 3/8-13 x 1
56	532154914	Bracket Asm., Susp Chassis Lh	--	532125085	Plug, Hole
58	532137113	Bracket Asm., Fender			
60	532171173	Screw 3/8-16 x 1-1/4			

NOTE: All component dimensions given in U.S. inches
1 inch = 25.4 mm

REPAIR PARTS

TRACTOR - MODEL NO. GTH250 (954140104B), PRODUCT NO. 954 14 01-04
GROUND DRIVE

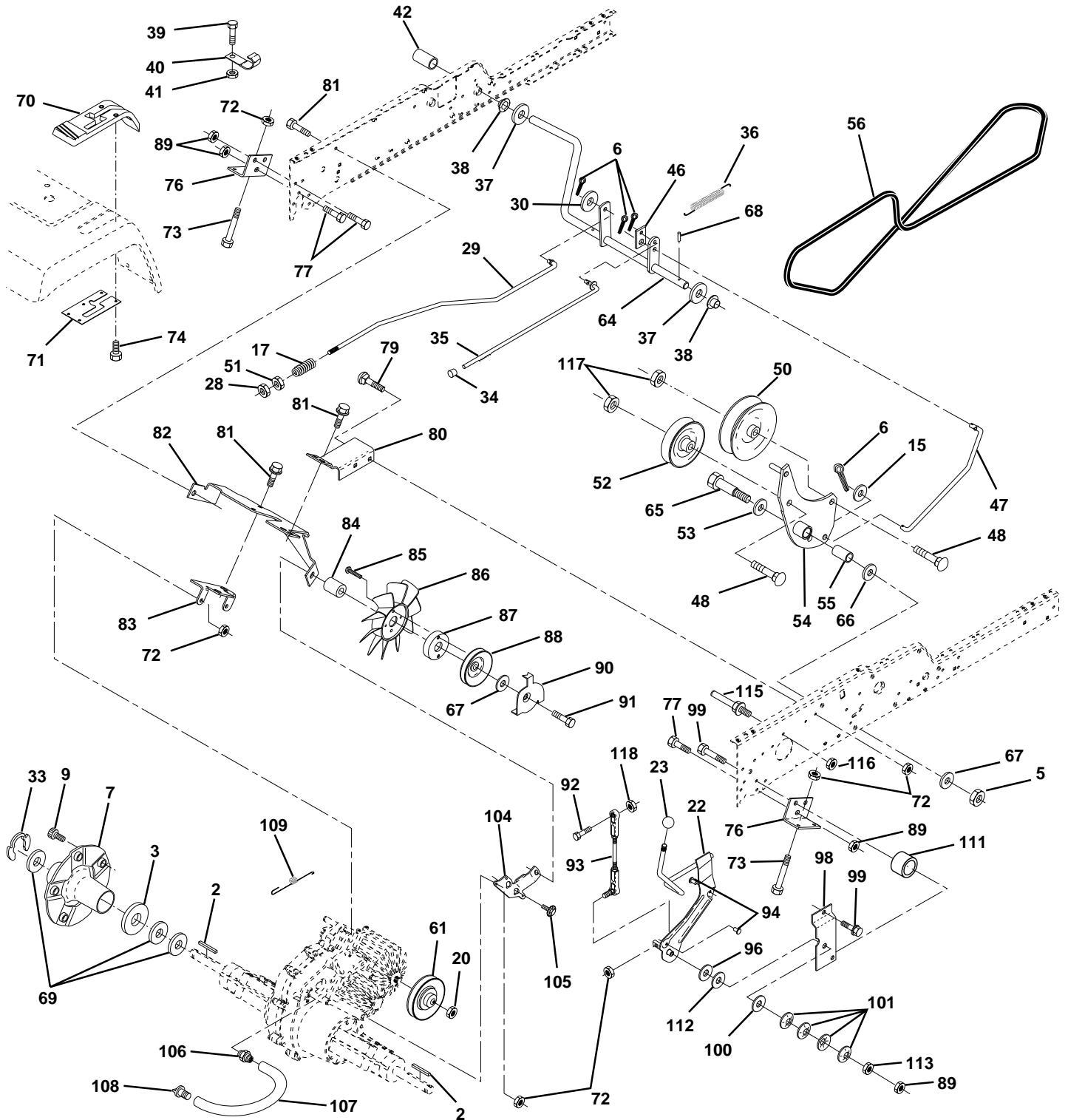

REPAIR PARTS

TRACTOR - MODEL NO. GTH250 (954140104B), PRODUCT NO. 954 14 01-04

GROUND DRIVE

KEY NO.	PART NO.	DESCRIPTION	KEY NO.	PART NO.	DESCRIPTION
1	-----	Transaxle , Hydro Gear 222-3010 Order parts from transaxle manufacturer	70	532166624	Console Hydro Fender
2	532007070	Key 1/4 x 2.5	71	532151179	Plate Console Shift
3	532007563	Washer Thrust Axle Harden	72	532171026	Nut Crownlock 5/16-18
5	532171168	Nut Crownlock 3/8-16	73	532171400	Bolt Hex FLGHD 5/16-18 x 3 Gr 5
6	532171165	Pin Cotter 1/8 x 3/4	74	532171370	Screw, Hex Wsh Hi-Lo 1/4-1/2
7	532140507	Wheel Hub Asm.	76	532140481	Bracket Transaxle
9	532171379	Bolt Hub	77	532171330	Bolt Fin Hex 7/16-14 x 1
15	532171168	Washer 13/32 x 13/16 x 16 Ga.	79	532171401	Bolt Carriage 5/16-18 x 5/8
17	532140921	Spring Rod Brake	80	532140484	Bracket Torque RH
20	532171128	Nut Hex Jam Toplock 1/2-20	81	532171154	Screw 3/8-16 x 3/4
22	532156103	Shaft Arm Asm	82	532150586	Bracket Mount Torque/Fan
23	532140845	Knob	83	532140479	Strap Torque Mid
28	532171163	Nut, Hex Jam 3/8-16	84	532140490	Spacer
29	532171404	Brake Rod	85	532171402	Screw #10-24 x 1-1/4
30	532171140	Washer 13/32 x 1 x 16Ga	86	532140462	Fan 7" Hydro
33	812000053	Ring E	87	532140491	Adapter Fan
34	532071673	Cap Plunger	88	532161592	Pulley Idler
35	532171459	Rod Parking Brake	89	532171331	Nut, Crownlock 7/16-14
36	532149412	Spring Drive Ground	90	532140489	Keeper Belt
37	532171038	Washer 25/32 x 1-1/4 x 16 Ga.	91	532171403	Screw Thdrol 3/8-16 x 2-3/4
38	532150035	Nyliner	92	532171409	Bolt Fin Hex 5/16-18 x 1.75
39	532171413	Screw Fin #10-24 x 1	93	532140502	Link Shift Asm
40	532005304	Actuator Interlock Switch	94	532133835	Fastner Christmas Tree
41	532171414	Nut Toplock #10-24 UNC	96	532141103	Washer Nickel Plated
42	532124872	Cover Pedal	98	532141004	Bracket Shift
46	532145170	Retainer Spring	99	532171411	Screw 3/8-16 x 1-1/2
47	532138228	Clutch Rod	100	532126881	Washer Compression
48	532171180	Bolt Carriage 3/8-16 x 1-1/2 Gr. 5	101	532156106	Washer Belleville
50	532131494	Pulley Idler Flat	104	532140480	Bracket Idler
51	532171408	Nut Lock Hex 3/8-16	105	532171399	Screw Tap 1/4-20 x 1/2
52	532139123	Pulley Idler Grooved	106	532142918	O-Ring Asm. Hydro Gear
53	532000207	Washer Hardened	107	532154739	Line Fuel Hydro
54	532161590	Clutch Arm Asm	108	532142917	Cap Vent
55	532105706	Bearing, Idler	109	532140929	Spring Return Brake
56	532140218	V-Belt	111	532156240	Spacer Shift Lever VGTH
61	532171484	Pullery Transaxle	112	532156104	Washer Nylon High Temp
64	532154752	Shaft Asm Brake Parking Clutch	113	532171412	Nut Hex ASF 7/16-14 UNC
65	532171423	Bolt Shoulder	115	532171428	Keeper Belt Gnd Dr.
66	532140296	Washer Hardened	116	532171429	Nut Lock Hex Flange 5/16-18
67	532171151	Washer 13/32 x 13/16 x 12 Ga	117	532171422	Nut Lock Flg. 3/8-16 UNC
68	532005142	Pin Roll	118	532171410	Nut Lock Hex w/Ins. 5/16-18 Unc
69	532171378	Washer			

NOTE: All component dimensions given in U.S. inches
1 inch = 25.4 mm

REPAIR PARTS

TRACTOR - MODEL NO. GTH250 (954140104B), PRODUCT NO. 954 14 01-04
STEERING ASSEMBLY

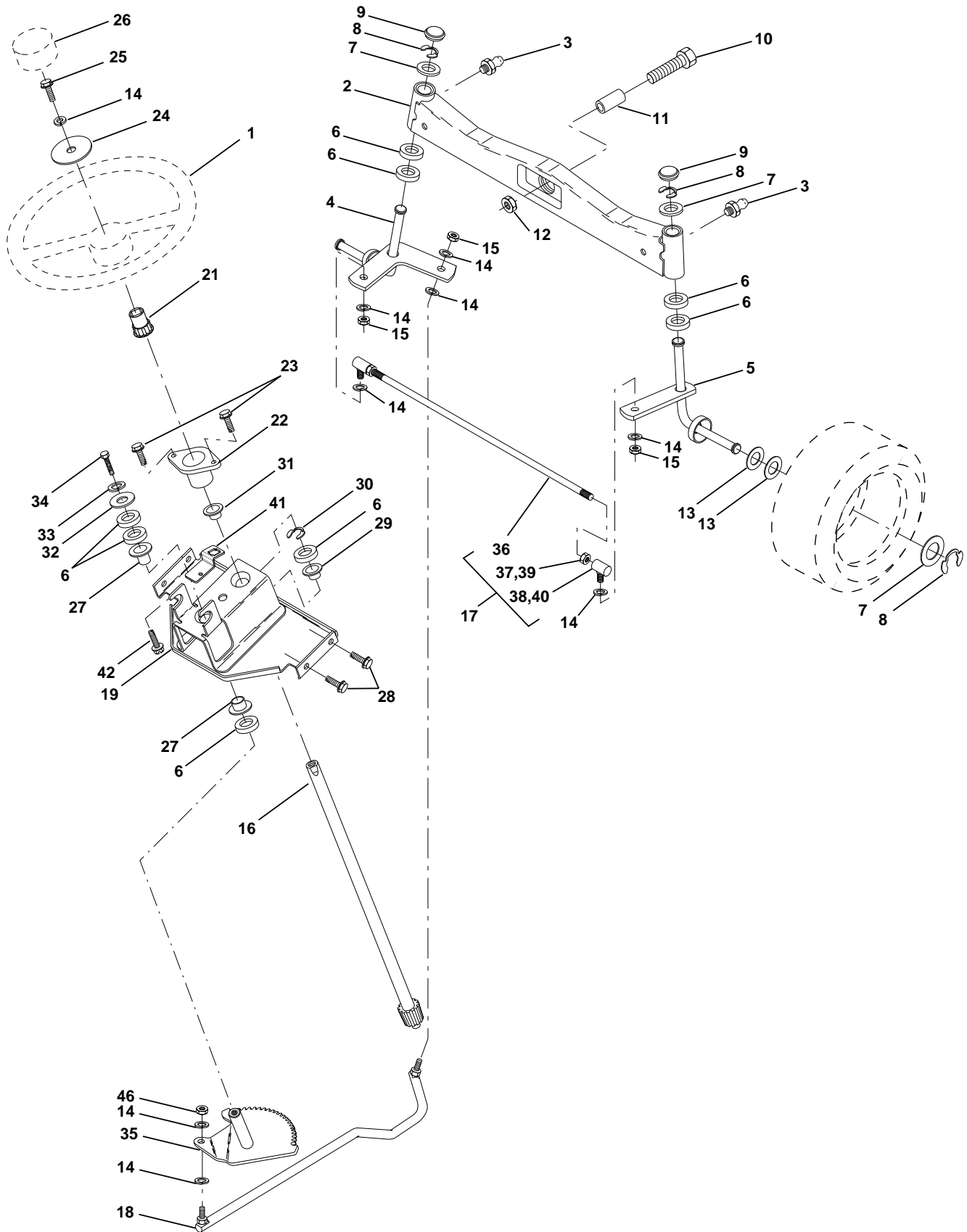

REPAIR PARTS

TRACTOR - MODEL NO. GTH250 (954140104B), PRODUCT NO. 954 14 01-04

STEERING ASSEMBLY

KEY NO.	PART NO.	DESCRIPTION
1	532166627	Wheel, Steering
2	532137094	Axle Asm., Front
3	532124836	Fitting, Grease
4	532161849	Spindle Asm, LH
5	532161848	Spindle Asm., RH
6	532124931	Bearing, Race Thrust Harden
7	532171039	Washer 25/32 x 1-5/8 x 16 Ga.
8	812000029	Ring, Klip #T5304-75
9	532121232	Cap, Spindle
10	532171415	Bolt, Fin Hex 5/8-11 x 2-3/4
11	532136518	Spacer, Brg. Axle Front
12	532171416	Nut, Lock Flange 5/8-11 Unc
13	532171038	Washer 25/32 x 1-1/4 x 16 Ga.
14	532171029	Washer, Lock Hvy Hlcl Spr 3/8
15	532171175	Nut, Lock Center 3/8-24 Unf
16	532145103	Shaft Asm., Steering
17	532137347	Rod Asm., Tie Ball J Ball Vgt (Inc. Key No. 36-40)
18	532137155	Draglink, Ball Joint Solid Vgt
19	532156011	Support Asm., Steering Vgt
21	532159945	Adapter, Wheel Steering
22	532155105	Bushing, Strg.
23	532171193	Screw
24	532171388	Washer 13/32 x 1-1/20 x 11 Ga.
25	532171427	Bolt, Fin Hex 3/8-16 x 1 Gr. 5
26	532166626	Cap , Wheel Steering
27	532124937	Bearing, Col. Strg.
28	532171154	Screw 3/8-16 x 3/4
29	532104239	Bearing, Flange
30	812000034	Ring, Klip Truarc #5304-75
31	532138136	Bushing, Nyliner Snap
32	532171425	Washer 11/32 x 1 x 10 Ga.
33	532171213	Washer, Lock Hvy Hlcl Spr 5/16
34	532171358	Bolt, Hex Hd 5/16-18 x 3/4
35	532138059	Gear, Sector Steering
36	532137156	Tie Rod
37	873360600	Jam Nut RH Thread
38	532109850	Joint Asm. Ball RH Thread
39	873700600	Jam Nut LH Thread
40	532109851	Joint Asm. Ball LH Thread
41	532155246	Bracket Switch Interloc
42	532171169	Screw Thdrol 5/16-18 x 1/2 Tyt
46	532171426	Nut Lock Center 3/8-24 Unf

NOTE: All component dimensions given in U.S. inches
1 inch = 25.4 mm

REPAIR PARTS

TRACTOR - MODEL NO. GTH250 (954140104B), PRODUCT NO. 954 14 01-04
ENGINE

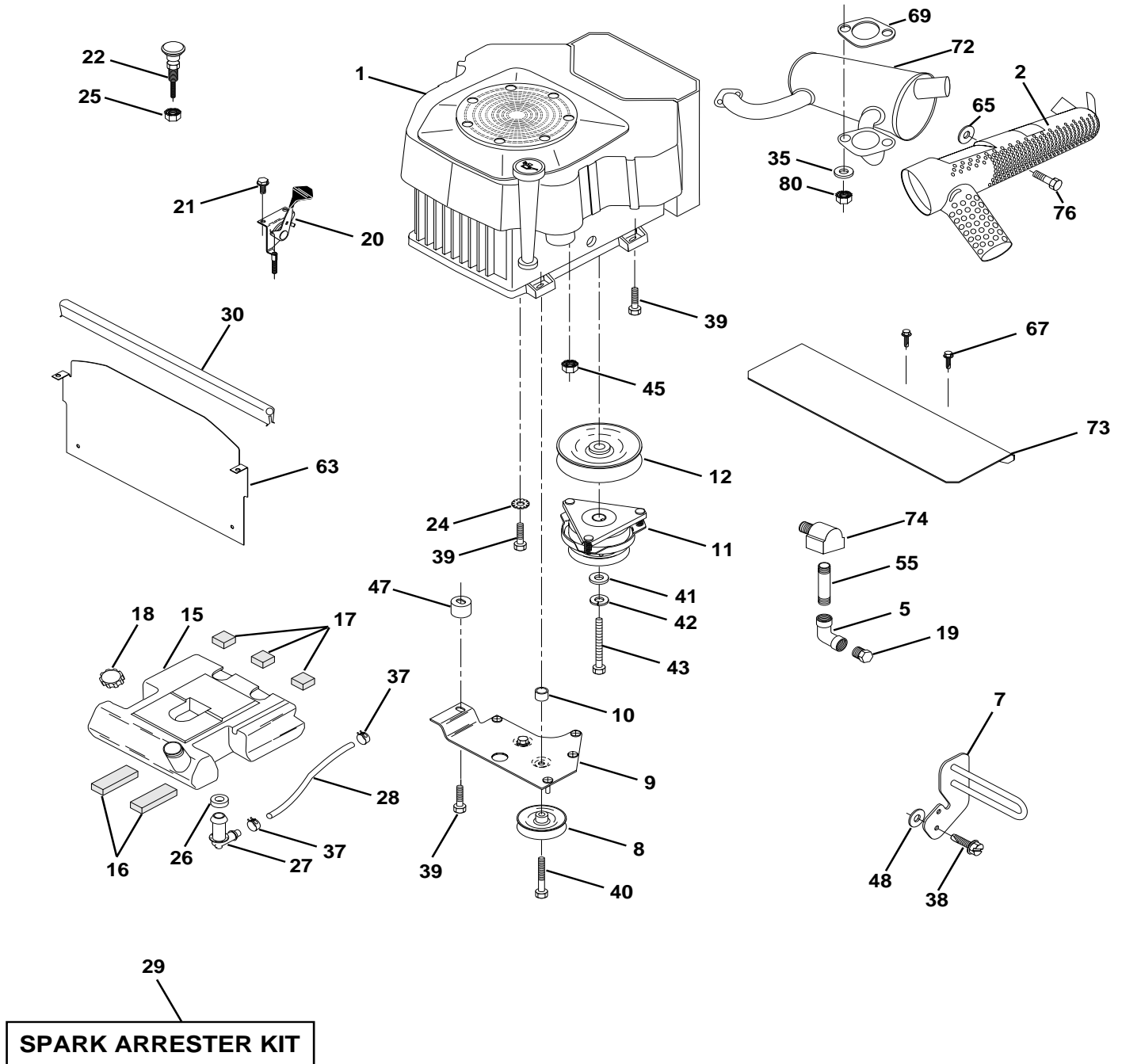

REPAIR PARTS

TRACTOR - MODEL NO. GTH250 (954140104B), PRODUCT NO. 954 14 01-04
ENGINE

KEY NO.	PART NO.	DESCRIPTION
1	-----	Engine Kohler, Model No. CV25S Order parts from engine manufacturer
2	532150249	Muffler Side
5	532171215	Elbow STD 90 Degree 3/8-18 NPT
7	532151396	Muffler Assembly Guard
8	532121361	Pulley V-Idler
9	532150828	Keeper Asm Belt Engine VGT 96
10	532105432	Bushing
11	532140923	Clutch Electric
12	532143996	Pulley Engine VGT Elect Clutch
15	532151346	Tank Fuel Rear
16	532109227	Pad Spacer
17	532106082	Pad Spacer
18	532140527	Cap Asm Fuel W/Sym Vented
19	-----	Plug Oil Drain (Order From Engine Manufacturer)
20	532142168	Control Throttle
21	532171192	Screw Hex Thd Cut 1/4-20 X 5/8
22	532145996	Control Choke
24	532171216	Washer Ext Tooth 3/8
25	532171350	Nut Keps 3/8 - 24 UNF
26	532124952	Bushing
27	532139277	Stem Tank Fuel
28	532124703	Fuel Line
29	532132920	Spark Arrester Kit
30	532161547	Extrusion Hood
35	532171467	Washer Split
37	532123487	Clamp Hose
38	532171466	Screw 3/8-16 x 1-1/4
39	532171476	Screw TT 3/8-16 x 2-1/4 UNC
40	532171479	Screw TT 3/8-16 x 4 UNC
41	532171480	Washer 1-1/2 OD X 15/32 ID X .250
42	532171220	Washer Lock 7/16
43	532171219	Bolt Hex 7/16-20 X 4-1/4 Ga 5
45	532171468	Nut Flange M8 1.25
47	532142040	Spacer Engine
48	532171556	Washer 13/32 x 1-1/4 x 7 Ga.
55	532171470	Nipple, Pipe 4-1/2"
63	532145549	Shield, Heat VGT YP/Husq.
65	532171236	Washer 13/32 x 1 x 14 Ga.
67	532171344	Screw 5/16-18 x 3/4
69	532163307	Gasket
72	532150250	Muffler Pre CV25
73	532153992	Shield Heat Muffler
74	532162295	Elbow Street Brass
76	532171154	Screw 3/8-16 x 3/4
80	532171468	Nut Flange M8 1.25

NOTE: All component dimensions given in U.S. inches
1 inch = 25.4 mm

REPAIR PARTS

TRACTOR - MODEL NO. GTH250 (954140104B), PRODUCT NO. 954 14 01-04
SEAT ASSEMBLY

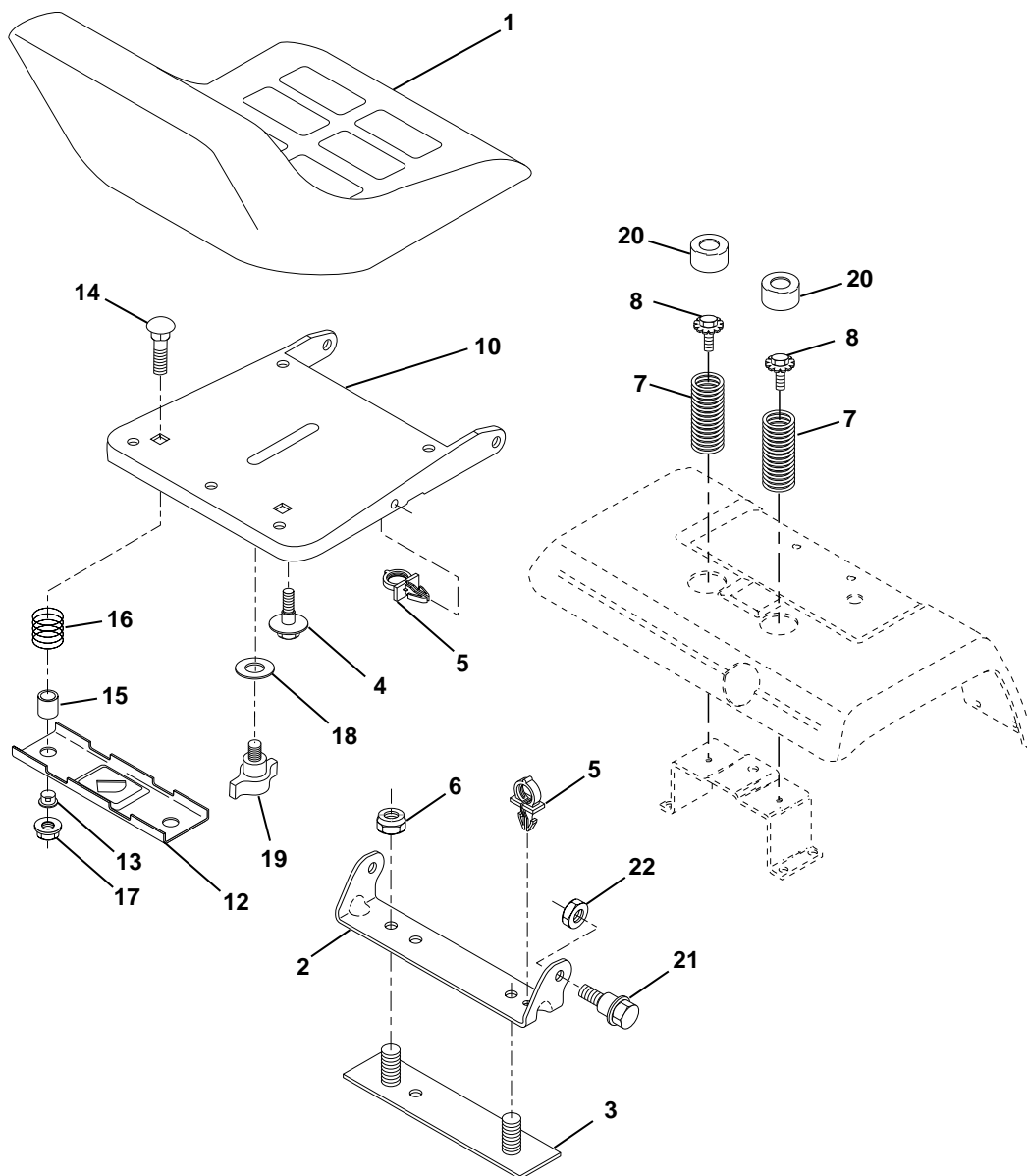

KEY NO.	PART NO.	DESCRIPTION
1	532141525	Seat
2	532140551	Bracket, Pivot Seat
3	532140675	Strap, Fender
4	532171260	Bolt, Shoulder 5/16-18 X .62
5	532145006	Clip, Push In Hinged
6	532171141	Nut, Lock Hex W/Ins. 3/8-16 Unc
7	532124181	Spring, Seat Cprsn
8	532171376	Bolt 5/16-18unc x 3/4 W/Sems
10	532155925	Pan, Seat
12	532121246	Bracket, Mounting Switch
13	532121248	Bushing, Snap

KEY NO.	PART NO.	DESCRIPTION
14	532171040	Bolt, Carriage 1/4-20 X 1-1/2
15	532121249	Spacer, Split
16	532123740	Spring, Cprsn
17	532171041	Nut, Lock 1/4 Lge Flg Gr. 5
18	532171261	Washer 17/32 X 1-3/16 X 12 Ga.
19	532166369	Knob, Seat
20	532124238	Cap, Spring Seat
21	532171130	Bolt, Shoulder 5/16-18 Unc-2A
22	532171026	Nut, Crownlock 5/16-18 Unc

NOTE: All component dimensions given in U.S. inches
1 inch = 25.4 mm

REPAIR PARTS

TRACTOR - MODEL NO. GTH250 (954140104B), PRODUCT NO. 954 14 01-04

DECALS

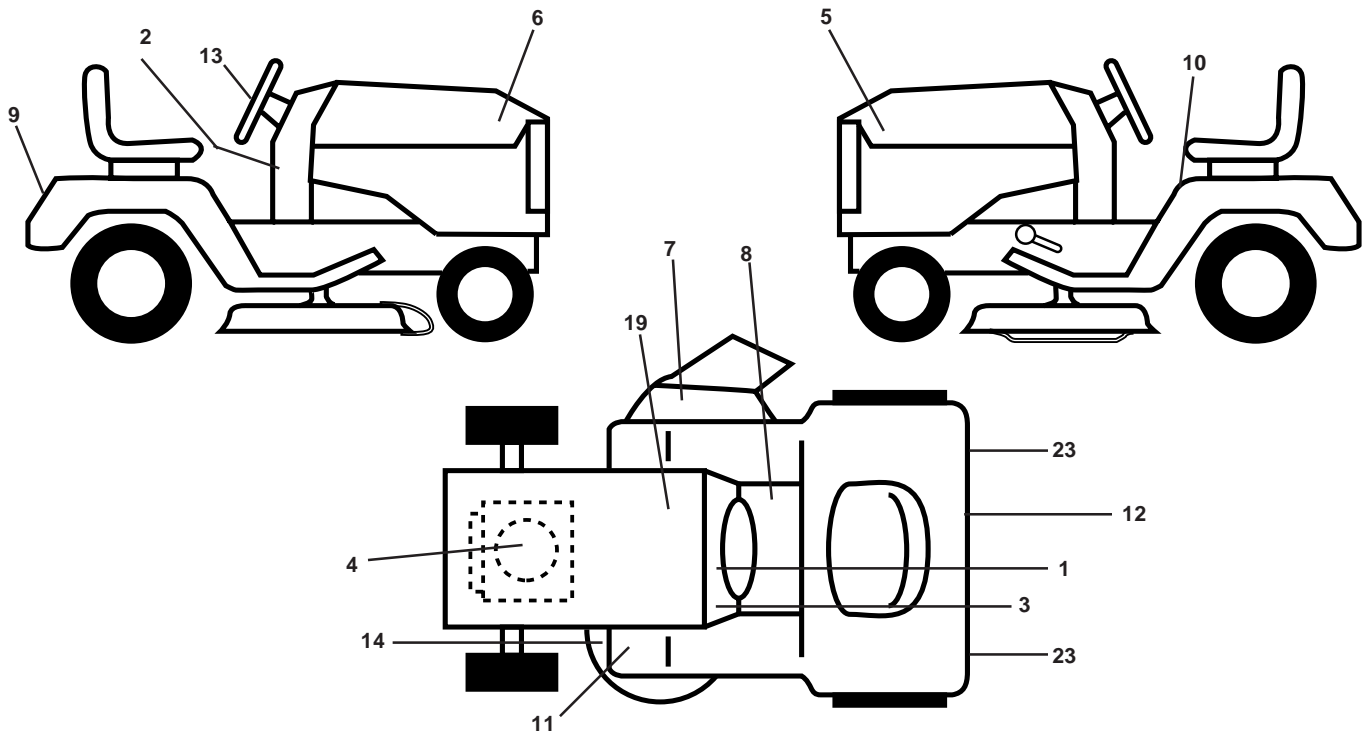

KEY NO.	PART NO.	DESCRIPTION	KEY NO.	PART NO.	DESCRIPTION
1	532156964	Decal, Operating Instruction	12	532142342	Decal, D-Bar Ctrl. Mvt Hyd YT/GT
2	532171458	Decal, Dash Logo	13	532170564	Decal, Wheel Steering
4	532170594	Decal, HP Engine	14	532160397	Decal, V-Belt Schematic
5	532170570	Decal, Hood LH	19	532145005	Decal, Battery
6	532170567	Decal, Hood RH	23	532106202	Reflector, Taillight
7	532170563	Decal, Warning	--	532138311	Decal, Handle Lft Height Adjust (Lift Handle)
8	532140837	Decal, Brake Parking Saddle	--	532171237	Pad Ftrest Sq Generic 97
9	532150617	Decal, Fender	--	532174478	Manual, Owner's (English)
10	532157140	Decal, Danger	--	532174479	Manual, Owner's (French)
11	532101892	Decal, Clutch/Brake			

WHEELS & TIRES

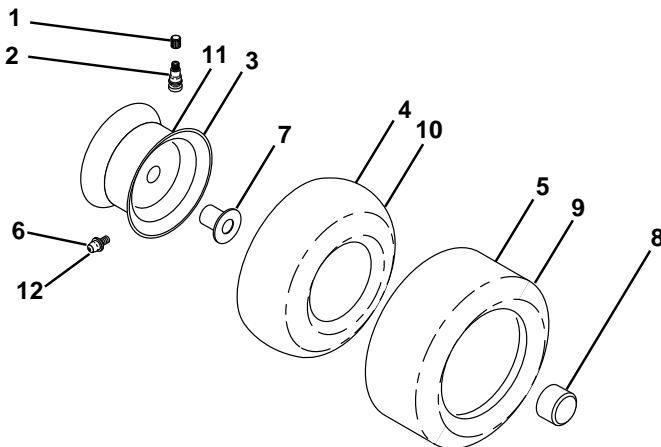

KEY NO.	PART NO.	DESCRIPTION
1	532059192	Cap, Valve, Tire
2	532065139	Stem, Valve
3	532144509	Rim Assembly, Front
4	532008134	Tube, Front (Service Item Only)
5	532106230	Tire, Front
6	532124957	Fitting, Grease
7	532124959	Bearing, Flange (Front Wheel Only)
8	532104757	Cap, Hub, Axle Blk.
9	532105588	Tire, Rear
10	532007154	Tube, Rear (Service Item Only)
11	532144510	Rim Assembly, Rear
12	532124860	Fitting Grease
--	532144334	Sealant, Tire (10 oz. Tube)

NOTE: All component dimensions given in U.S. inches
1 inch = 25.4 mm

REPAIR PARTS

TRACTOR - MODEL NO. GTH250 (954140104B), PRODUCT NO. 954 14 01-04

LIFT ASSEMBLY

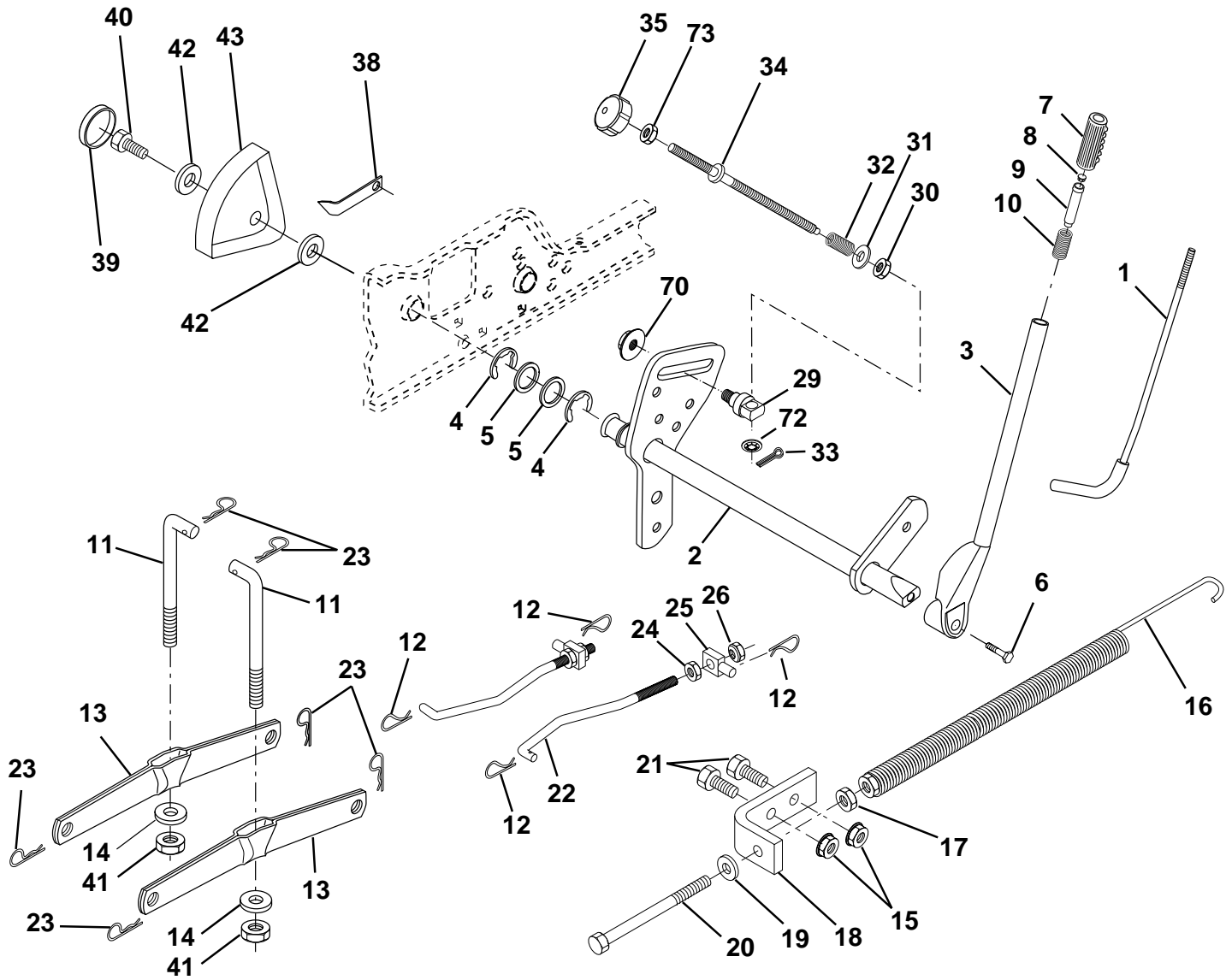

REPAIR PARTS

TRACTOR - MODEL NO. GTH250 (954140104B), PRODUCT NO. 954 14 01-04

LIFT ASSEMBLY

KEY NO.	PART NO.	DESCRIPTION
1	532121006	Rod Asm., Lever
2	532159187	Shaft Asm., Lift Vgt
3	532159189	Lever Asm., Lift Rh
4	812000022	E-Ring Truarc #5133-87
5	532171182	Washer 29/32 x 1-1/4 x 16 Ga.
6	532171362	Bolt, Fin Hex 3/8-16 x 1-1/2
7	532125631	Grip, Handle Fluted
8	532124526	Button, Plunger
9	532122364	Plunger, Lever Lift
10	532124874	Spring 2-1/8"
11	532146704	Link Lift
12	532171212	Retainer, Spring
13	532139868	Arm, Suspension Vgt
14	532169865	Bearing
15	532171168	Nut, Crownlock 3/8-16 Unc
16	532124687	Spring Asm., Assist Lift
17	532171357	Nut, Hex Jam 3/8-16 Unc
18	532143363	Bracket, Spring Assist
19	532171140	Washer 13/32 x 13/16 x 16 Ga.
20	532171418	Bolt, Adjust Spring Assist
21	532171339	Bolt, Fin Hex 3/8-16 x 1
22	532127218	Link, Front
23	532171211	Retainer, Spring
24	873350800	Nut, Jam Hex 1/2-13 Unc
25	532130171	Trunnion
26	873680800	Nut, Crownlock 1/2-13 Unc
29	532171203	Trunnion, Infin Height
30	532171355	Nut, Special
31	532171207	Washer 13/32 x 5/8 x 16 Ga.
32	532137150	Spring, Compression Inf Hgt
33	532171359	Pin, Cotter 3/32 x 1/2
34	532171353	Rod, Adj Lift
35	532138057	Knob, Inf 3/8-16 Unc
38	532155097	Pointer, Height Indicator
39	532123935	Plug, Hole
40	532171210	Screw 5/16-18 x 1
41	873540600	Nut, Crownlock 3/8-24
42	532171209	Washer 11/32 x 1-1/2 x 10 Ga.
43	532123934	Scale, Indicator Height
70	532171178	Nut Hex Flange Lock
72	532110452	Nut Push Phos & Oil
73	532171357	Nut Hex Jam 3/8-16 Unc

NOTE: All component dimensions given in U.S. inches
1 inch = 25.4 mm

REPAIR PARTS

TRACTOR - MODEL NO. GTH250 (954140104B), PRODUCT NO. 954 14 01-04
MOWER DECK

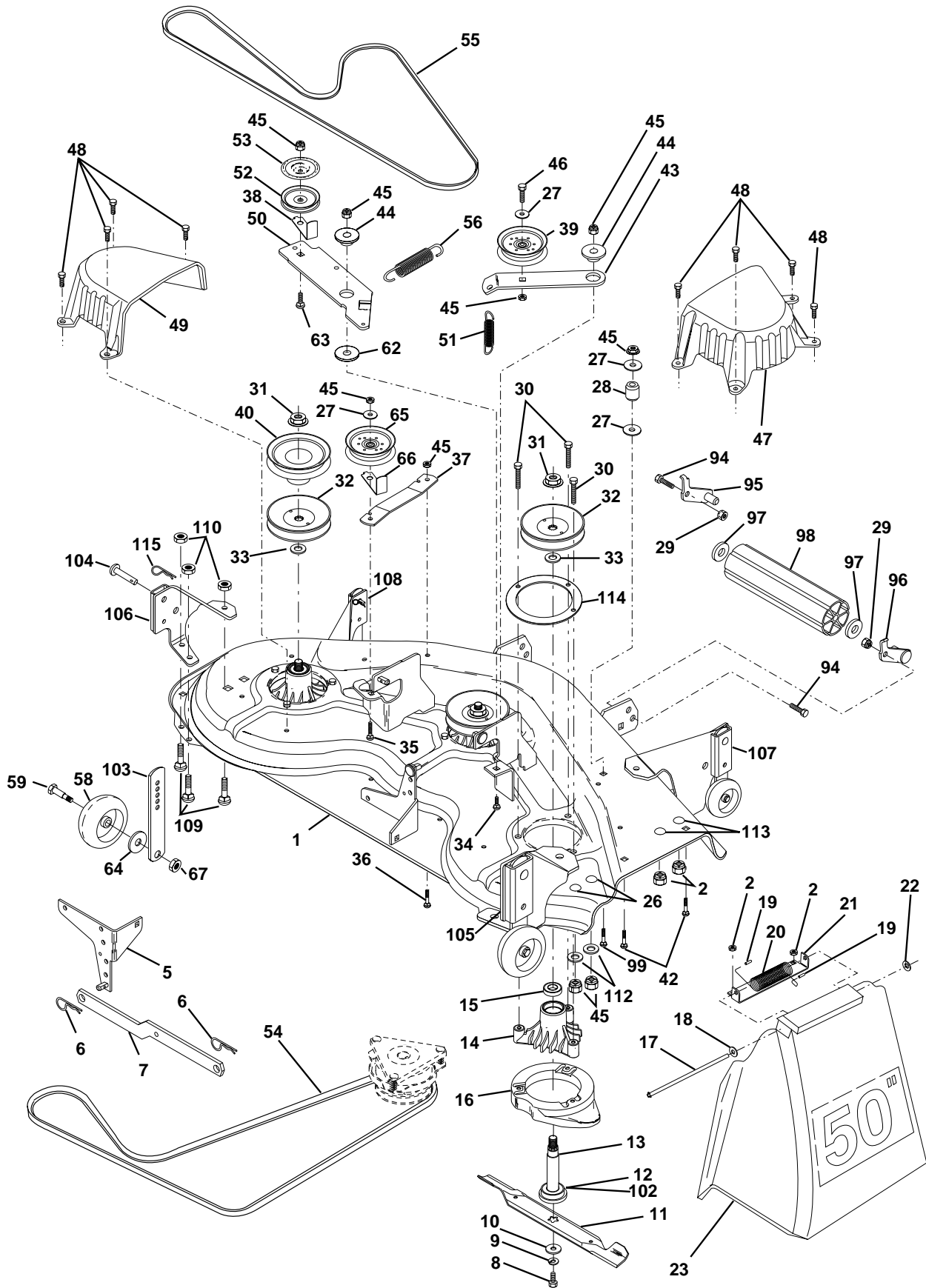

REPAIR PARTS

TRACTOR - MODEL NO. GTH250 (954140104B), PRODUCT NO. 954 14 01-04

MOWER DECK

KEY NO.	PART NO.	DESCRIPTION	KEY NO.	PART NO.	DESCRIPTION
1	532156990	Deck Asm., Mower 50" Vented	49	532136574	Cover, Mandrel LH
2	532171248	Nut, Crownlock 5/16-18 Unc	50	532137272	Arm, Idler Primary
5	532138457	Bracket Asm., Sway Bar	51	532137273	Spring, Secondary
6	532171170	Retainer, Spring	52	532139245	Pulley, Idler V Groove
7	532130832	Arm Suspension, Rear	53	532137789	Shield, Idler
8	532850857	Bolt 3/8-24 x 1.25 Gr. 8 Patched	54	532139573	V-Belt, Mower Primary
9	532171241	Washer, Lock Hvy 3/8 Unplated	55	532144959	V-Belt, Mower Secondary
10	532140296	Washer, Hard Blade Mower Vented	56	532138687	Spring, Primary
11	532137380	Blade (3 Required)	58	532133957	Wheel, Gauge
12	532129895	Bearing, Ball #6204 (Mandrel)	59	532171254	Bolt, Shoulder
13	532137553	Shaft Asm., W/Lower Brg (Includes Key No. 12)	62	532133943	Washer Hardened
14	532137152	Housing, Mandrel 50" Vent	63	532171180	Bolt Carriage 3/8-16 x 1-1/2
15	532110485	Bearing, Ball Mandrel	64	532171256	Washer 3/8 x 7/8 x 14 Ga.
16	532140329	Stripper, Mower Vented	65	532151831	Pulley Idler Flat Mower
17	532171594	Rod, Hinge	66	532156009	Keeper, Belt Idler 44/50" Vent
18	532171222	Washer 11/32 x 5/8 x 16 Ga.	67	532171255	Nut, Center Lock 3/8-16
19	532105304	Cap, Sleeve	94	532171375	Bolt, Fin Hex 3/8-16 UNC x 1
20	532123713	Spring, Torsion Deflector	95	532132274	Bracket, Asm. Noseroller LH
21	532137607	Bracket, Deflector	96	532132273	Bracket, Asm. Noseroller RH
22	532110452	Nut, Push	97	532171389	Washer 17/32 x 7/8 x 16 Ga.
23	532171593	Shield, Deflector Mower	98	532132264	Roller, Nose
26	532171576	Bolt Rdhd Sht Sqnk 3/8-16 x 3/4	99	532171578	Bolt, Carriage 3/8-16 x 1-3/4 Gr. 5
27	532171140	Washer 13/32 x 13/16 x 16 Ga.	102	532153390	Washer Felt
28	532132823	Spacer, Spring Stop Idler	103	532155986	Bar Pnt Adjusting Wheel Gauge
29	532171141	Nut, Lock Hex W/Wsh 3/8-16 Unc	104	532171386	Pin Head Rivet
30	532171244	Screw Tdhrolling Washer Head	105	532156852	Bracket Whl Ga. Asm Rear RH 50"
31	532171246	Nut, Flg Top Lock Cntr 9/16	106	532156853	Bracket Whl Ga. Asm. Rear LH 50"
32	532153535	Pulley, Mandrel	107	532156854	Bracket Whl Ga. Asm. Front RH 50"
33	532171245	Washer, Spacer Mower Vented	108	532156856	Bracket Whl Ga. Asm Front LH 50"
34	532171383	Bolt, Carriage 3/8-16 x 1-1/4	109	872010505	Bolt Carriage 5/16-18 x 5/8 Blk
35	532171586	Bolt, Carriage 3/8-16 x 2	110	873980500	Nut Crownlock 5/16-18 Blk
36	532171250	Bolt, Carriage 3/8-16 x 1 Gr. 5	112	532171230	Washer 17/32 x 3/4 x 16 Ga.
37	532137166	Stiffener, Arm Idler	113	532171587	Bolt Carriage 5/16-UNC x 1/2
38	532156085	Keeper, Belt Idler	114	532153183	Reinforcement Mandrel Ring
39	532131494	Pulley, Idler Flat	115	532171211	Retainer Spring Blk D
40	532136572	Pulley, Driven	--	532143651	Mandrel Asm (Includes Key Nos. 8-10, 12-15, 31 and 33)
42	532171249	Bolt, Carriage 5/16-18 Unc x 3/4	--	532171317	Mower Asm Service (Std. Deck - Order separately all Nose Roller and all Gauge Wheel components)
43	532136460	Arm, Idler Secondary			
44	532165723	Spacer, Retainer			
45	532171168	Nut, Crownlock 3/8-16 Unc			
46	532171585	Bolt, Fin Hex 3/8-16 Unc x 1-3/4			
47	532137200	Cover, Mandrel RH			
48	532171253	Screw, Thd Roll 1/4-20 x 5/8			

NOTE: All component dimensions given in U.S. inches
1 inch = 25.4 mm